

**FORWARD**  
*LIFT*

# FCH4

## MOBILE COLUMN LIFTING SYSTEM

### BATTERY OPERATED WITH INTERNAL CHARGER

No power cords to clutter up the service bay, improving portability.

### INVERTED HYDRAULIC CYLINDER

The chrome piston rod is protected from debris and damage at all times extending the life of the product and substantially reducing maintenance costs.

### AUTOMATIC STEERING SYSTEM

No need to manually pump the jacks up to move the columns in and out

### FORKLIFT POCKETS

Relocate column in your shop with ease.



Shown:  
FCHU2F4001

### FIXED FORKS

Fit most large truck tires without adjustment (reducer sleeves available)

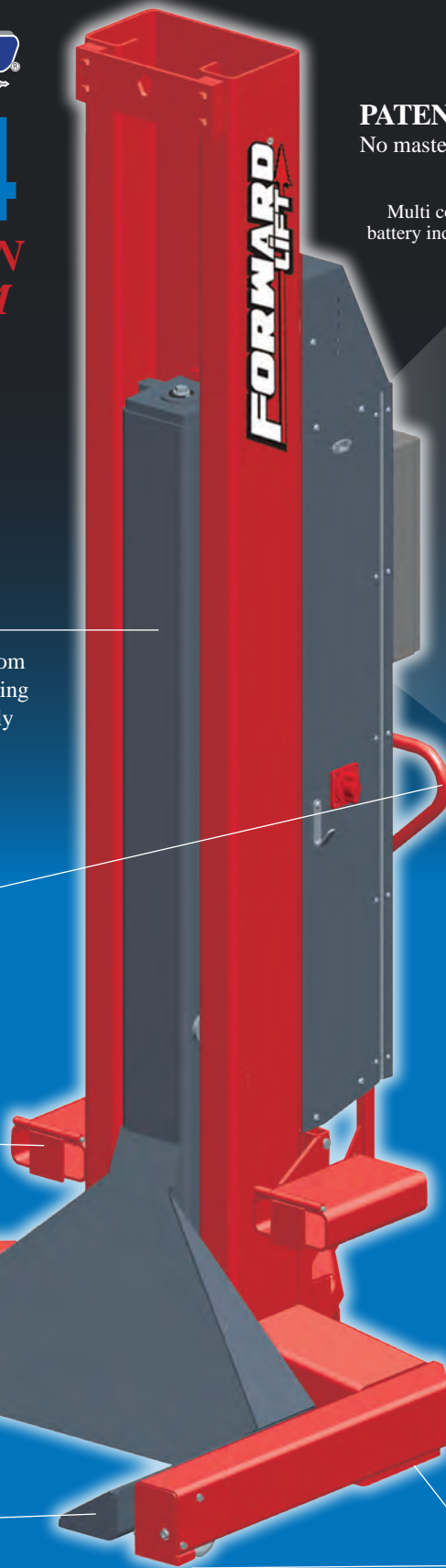

### PATENTED CONTROL SYSTEM

No master/slave column - lift can be controlled from any column



### QUICK CONNECT CABLES

Lightweight, easy to connect and 33 feet long

### HORSESHOE WIRING

While other mobile column lifts are connected by four cables, the wired FCH4 uses just three (forming a horseshoe), so the front or back of the lift is always open.

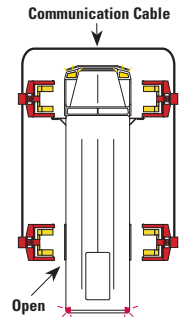

**USE THE LIFT  
ON ANY CONCRETE  
SURFACE**

*Engineered to perform... Built to last!*

[WWW.FORWARDLIFT.COM](http://WWW.FORWARDLIFT.COM)

**FORWARD**  
*LIFT*

**GET THE MOST FROM  
YOUR LIFTING  
SYSTEM!**

# FCH4 **FORWARD** **LIFT**

## MOBILE COLUMN ACCESSORIES

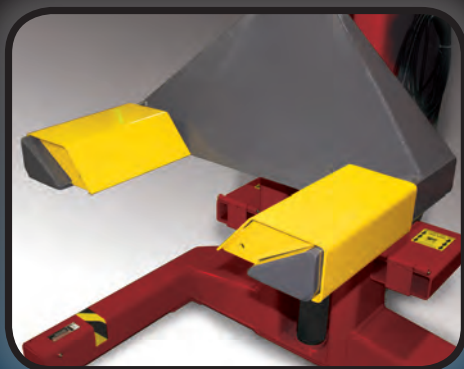

### REDUCER SLEEVES

Steel reducer sleeves slide onto the forks to allow proper contact with smaller radius tires.

(14" to 20" tires / 356-508mm)

Shown: M140071

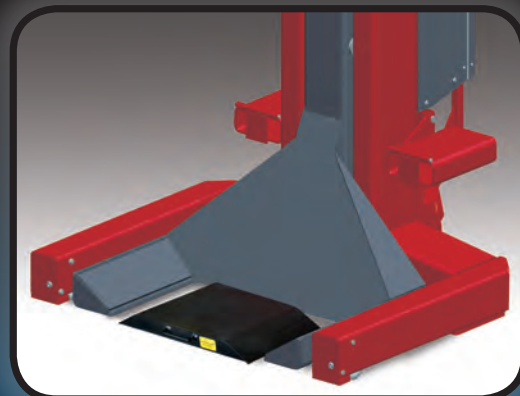

### LARGE WHEEL RISER KIT

Larger tires are raised on ramps to allow for proper fork placement.

Shown: M140030

### LED LIGHTING

High-efficiency LED lighting with convenient, single touch operation at the control panel provides hands-free lighting under the vehicle.



Shown: M140002



### JACK STANDS

Available in 18,000 and 33,000 lbs. capacities with spring loaded caster wheels for easy positioning and portability.



Shown: RS18  
18,000 lbs. capacity tripod stand

### SPECIFICATIONS

MOBILE LIFT	FCH4	FCH6	FCH8
Column configuration	4	6	8
Capacity	72,000 lbs.	108,000 lbs.	144,000 lbs.
Rise		70" (1778 mm)	
Lifting cycles		12-14 per charge	
Column width		45.5" (1156 mm)	
Column height Height at full stroke		102" (2590mm) 144.75" (4464mm)	
Tire Dimensions	21" to 24" (533 - 610 mm) Truck road tires		
Clearance from fork to column	10" (254 mm)		
Speed of rise	78 seconds		
Charging voltage	110v-240v / 50/60Hz charger*		
Battery type	NG - 24 to 27*		

\* Call factory for alternate voltage \* Batteries not included - requires 2 per column

### OPTIONAL WEIGHT GAUGE

Gauges approximate the weight being lifted by one column - turning pressure into weight.



Shown: M140019



Forward Lift  
996 Industrial Drive  
Madison, IN 47250

Phone: 800.423.1722  
Fax: 812.273.7329  
www.forwardlift.com



Lit# Forward FCH4\_Mobile\_Cutsheet\_2011.12

©2011 Forward Lift, Forward Lift is a brand of Vehicle Service Group, A Dover Company. All rights reserved. Unless otherwise indicated, Forward Lift, Vehicle Service Group, Dover and all other trademarks are property of Dover Corporation and its affiliates.

Exclusive Mobile Column Controls / U.S. Patent No. 6,983,196