

FLR12 - LUBE RACK

Engineered to perform... Built to last!

**Increase your oil
change revenue
with Forward Lift's
NEW Lube Rack!**



Shown: FLR12-EL2
12,000 lbs. capacity
lube rack
Shown with optional
front mezzanine
with balcony
(S100105)

Engineering Excellence

Forward's U.S. engineers have over 29 years of combined experience designing automotive lifts for service and repair shops. Forward's philosophy is to own our designs rather than use someone else's off the shelf product.

Product Integrity

21st century design tools allow us to create, control and validate our designs to ensure maximum performance. Forward lifts are rigorously tested to meet quality and durability standards. All product families are proof load tested to 1½ times rated capacity and rigorously cycle tested.



**Four-Post
FLR12
is Gold
Certified**

**FORWARD
LIFT**

FLR12 FEATURES & BENEFITS

FEATURES:

- 12,000 capacity will service most cars and light trucks
- Multiple configurations to meet variable bay sizes
- 4 horsepower motor for faster rise
- Lifting cylinder under the runway
- Chrome plated pins, heavy duty sheaves and cables
- 30 gallon (120 quart) oil drain pan included
- Non-skid coating on ladder steps
- ETL tested and certified
- Lifts available with or without ladders (must specify when ordering)
- FLR12 - cable driven four post quick lube. Ladder (optional) located on right hand side. Can be combined in multiple units for multi-bay operation



Shown: FLR12-EL2



12,000 lbs. capacity lube rack
Shown with optional front mezzanine with balcony (S100105)

Kits are available to connect fixed mezzanines in multi-bay systems so that one man can work on multiple lifts without having to walk up and down the ladder.

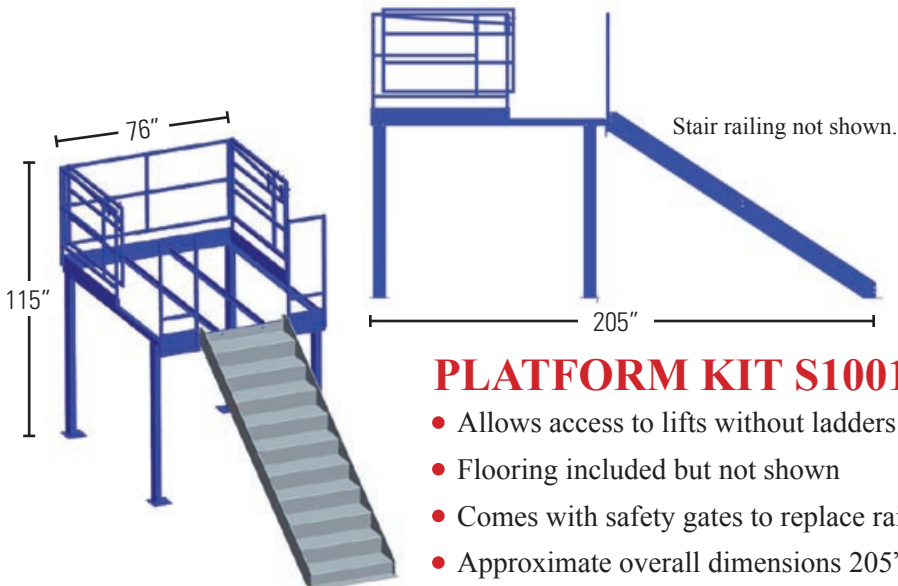

PLATFORM KIT S100111

- Allows access to lifts without ladders
- Flooring included but not shown
- Comes with safety gates to replace railing
- Approximate overall dimensions 205"x76"x115"
- Stationary platform with steps to go in between lifts for multi-bay operation 75"x97" platform.

MEZZANINE STAIR KIT

Kit 120K21 = 24"x48"

Kit 120K20 = 24"x64"

front mezzanine connector-walk area connecting multi-bay systems, includes stairs. Shown as #1 on next page.

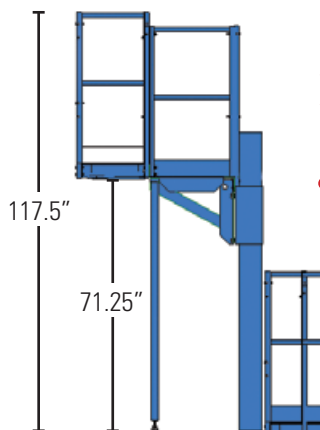

MEZZANINE KIT S100105

- Fixed front Mezzanine with balcony stationary platform in front of lift 25"x128" and balcony attached to front mezzanine 22"x69". Shown as #4 on next page.

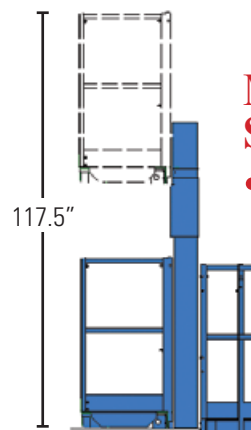

MEZZANINE KIT S100106

- Moving front mezzanine elevates and descends with lift 31"x101". Shown as #6 on next page.

Six options to fit your needs:

1 Dual lift system with connector package, optional mezzanine and balconies

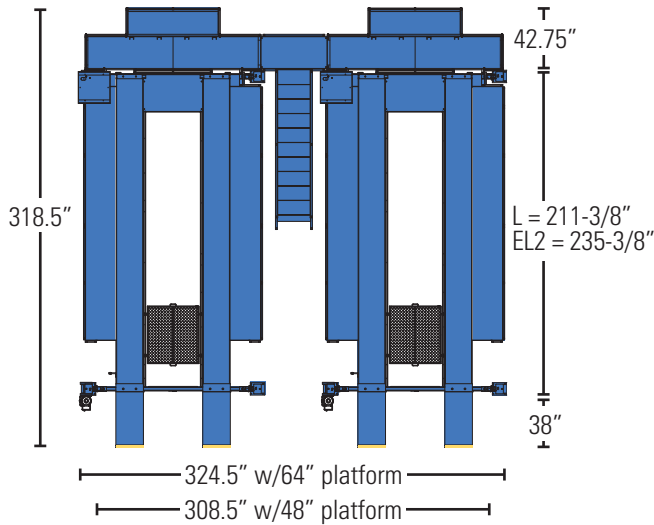

2 Dual lift system with middle platform and drive through operation

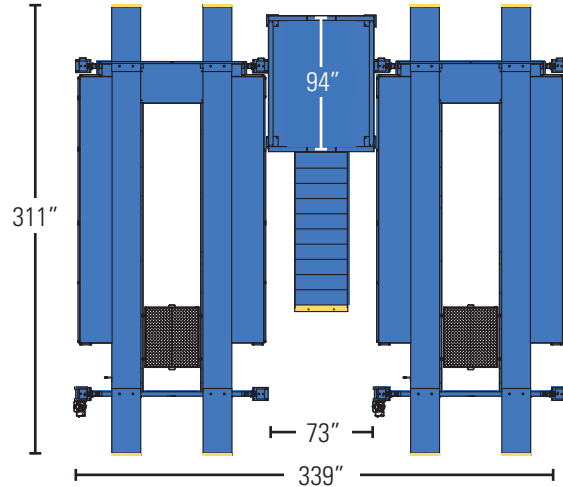

3 Single lift with optional fixed mezzanine

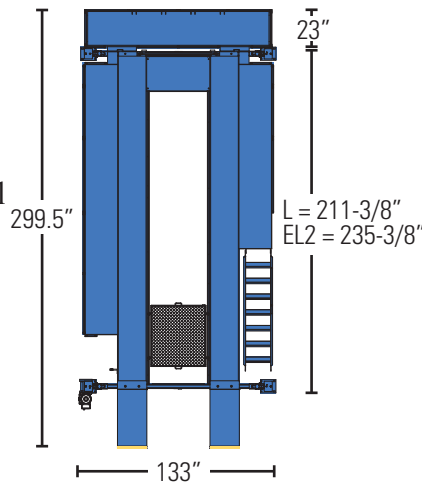

4 Single lift with fixed mezzanine and optional balcony

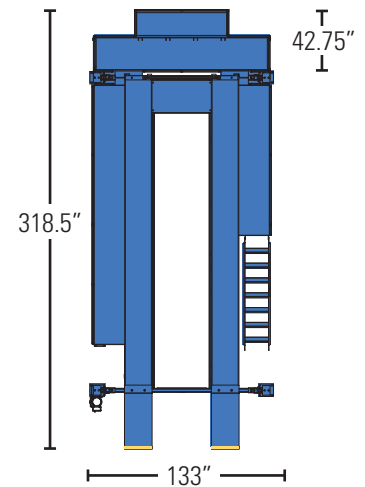

5 Single lift with drive through operation

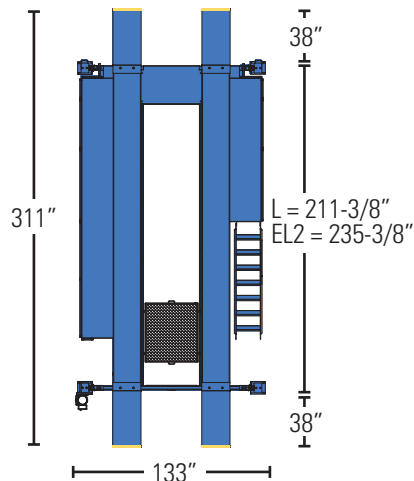

6 Single lift with movable mezzanine

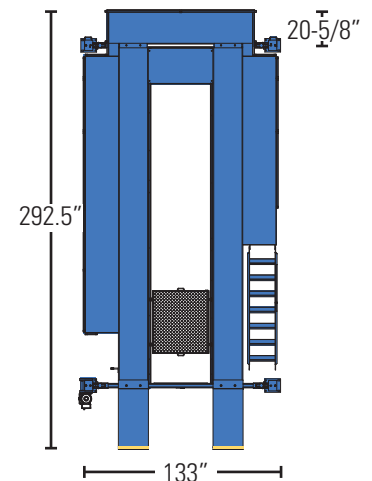

Other configurations are possible due to the FLR12's unique modular design. Use kits to build the lift configuration that meets your needs.

Shown with ladder.

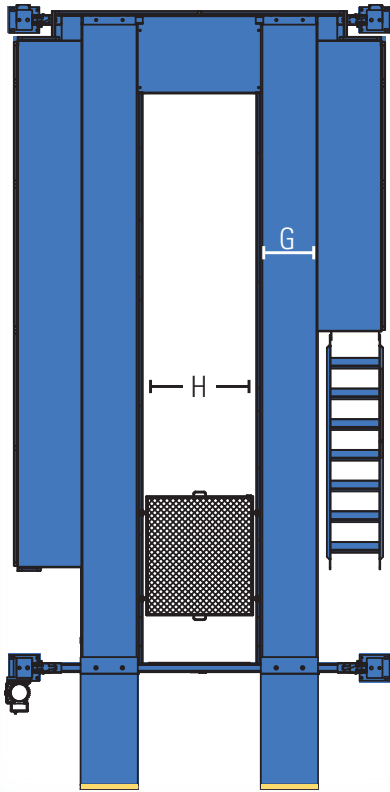

Model Specifications:

	FLR12	FLR12-EL2
Capacity	12,000 lb.	12,000 lb.
A. Rise	66"	66"
B. Overall Length	251"	275"
C. Overall Height	118.5"	118.5"
D. Overall Width	133"	133"
E. Drive Thru Clearance	110-3/4"	110-3/4"
F. Width Between Columns	117-1/2"	117-1/2"
G. Runway Width	20"	20"
H. Width Between Runways	39-5/8"	39-5/8"
Walkway Width	22-1/8"	22-1/8"
Wheelbase	182"	206"
Rise Time*	60 seconds	60 seconds
Power	1Ø/60Hz or 3Ø/60Hz, 208-460 volts, 4 hp	1Ø/60Hz or 3Ø/60Hz, 208-460 volts, 4 hp

*At rated capacity

Specifications subject to change without notice or liability

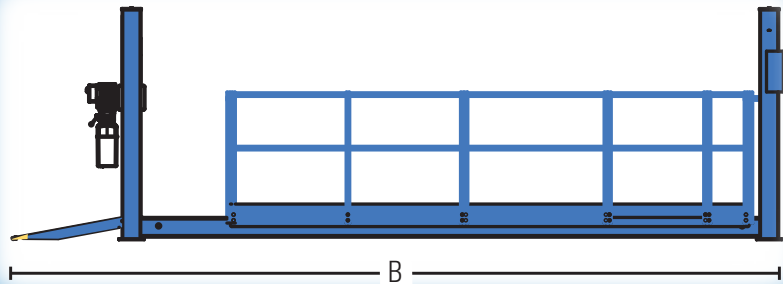
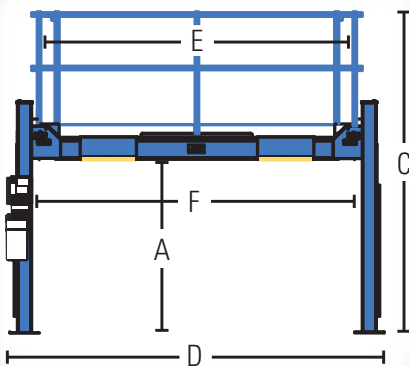

Shown: FLR12-EL2



12,000 lbs. capacity
lube rack
Shown with optional
front mezzanine
with balcony
(S100105)



Forward Lift
996 Industrial Drive
Madison, IN 47250

Phone: 800.423.1722
Fax: 812.273.7329
www.forwardlift.com

Lit# Forward FLR12_2009.11

©2009 Forward Lift. Forward Lift is a brand of R.L. Consolidated, A Dover Company. All rights reserved. Unless otherwise indicated, Forward Lift, R.L. Consolidated, Dover and all other trademarks are property of Dover Corporation and its affiliates.