

MID-RISE 6,000 POUND CAPACITY

Installation and Operation Manual

994417

Table of Contents

<u>Chapter/Paragraph</u>	<u>Page</u>
Safety Summary	iv
General Safety Instructions	iv
Warnings, Cautions, and Notes.....	iv
1 General Information and Specifications.....	1-1
1.1 General Information.....	Error! Bookmark not defined.
1.2 Specifications	1-1
1.2.1 General Specifications	1-1
2 Installation and Preparation for Use	2-1
2.1 General Information.....	2-1
2.2 Tools and Equipment Required	2-1
2.3 Foundation Requirements	2-1
2.4 Installation	2-1
2.4.1 Mount Motor and Pump.....	2-1
2.4.2 Hydraulics and Safety Cable Installation and Servicing	2-2
2.5 Installation test.....	2-4
3 Operating Instructions.....	3-1
3.1 Safety Procedures	3-1
3.2 Daily Pre-Operation Check (8-Hours).....	3-1
3.3 Controls	3-2
3.4 Operation.....	3-3
3.4.1 Raising Vehicle.....	3-5
3.4.2 Lowering Vehicle	3-6
4 Maintenance and Troubleshooting	4-1
4.1 Maintenance	4-1
4.1.1 Owner/Employer Responsibilities.....	Error! Bookmark not defined.
4.1.2 Periodic Maintenance Schedule.....	4-1
4.1.2.1 Daily Pre-Operation Check (8-Hours)	4-1
4.1.2.2 Monthly Maintenance (every month).....	4-1
4.1.2.3 Special Maintenance Tasks	4-2
4.2 Troubleshooting.....	4-2
4.2.1 Motor Does Not Operate	4-2
4.2.2 Lift Mechanism Does Not Move Up and Down Smoothly.....	4-3
4.2.3 Lift Does Not Lift its Rated Capacity.....	4-3
4.2.4 Cylinders Leak under Rated Load.....	4-3
4.2.5 Lift will not lower.....	4-3
Lift Lockout/Tagout Procedure	4-3
Operating Conditions.....	4-4
5 Illustrated Parts Breakdown.....	5-4
5.1 Illustrated Parts Breakdown Information.....	5-4
5.2 Complete Parts Listing	5-12
5.2.1 Hardware Bag #1	5-12
5.2.2 Master (Complete) Parts Listing.....	5-12

List of Figures

<u>Figure</u>	<u>Page</u>
Figure 2-1. Motor and Pump Mounting	2-2
Figure 2-2. Hydraulics and Safety Cable Installation and Servicing	2-4
Figure 3-1. Controls	3-2
Figure 5-1. Illustrated Parts Breakdown – Sheet 1 of 3	5-5
Figure 5-1. Illustrated Parts Breakdown – Sheet 2 of 3	5-8
Figure 5-1. Illustrated Parts Breakdown – Sheet 3 of 3	5-10

List of Tables

<u>Table</u>	<u>Page</u>
Table 1-1. General Specifications	1-1
Table 1-2. Lift Capacity Specifications	1-1
Table 3-1. Controls	3-2
Table 5-1. Parts Listing – Page 1 of 3.....	5-6
Table 5-1. Parts Listing – Page 1 of 3 (Cont.).....	5-6
Table 5-1. Parts Listing – Page 2 of 3.....	5-9
Table 5-1. Parts Listing – Page 3 of 3.....	5-11
Table 5-2. Hardware Bag #1 Contents	5-12
Table 5-3. Master (Complete) Parts Listing	5-12
Table 5-3. Master (Complete) Parts Listing (Cont.)	5-13

Safety Summary

General Safety Instructions

This summary describes physical and chemical processes that may cause injury or death to personnel, or damage to equipment if not properly followed. This safety summary includes general safety precautions and instructions that must be understood and applied during operation and maintenance to make sure that personnel safety and protection of equipment is observed. Prior to performing any task, the WARNINGS, CAUTIONS, and NOTES included in that task should be reviewed and understood.

Warnings, Cautions, and Notes

WARNINGS and CAUTIONS are used in this manual to highlight operating or maintenance procedures, practices, conditions or statements that are considered essential to protection of personnel (WARNING) or equipment (CAUTION). WARNINGS or CAUTIONS immediately precede the step or procedure to which they apply. NOTES are used in this manual to highlight operating or maintenance procedures, practices, conditions or statements that are not essential to the safeguarding of personnel or equipment. NOTES may precede or follow the step or procedure, depending on the information to be highlighted. The Headings used and their definitions are as follows.

WARNING

Highlights essential operating or maintenance procedure, practice, condition, statement, etc. that if not strictly observed, could result in injury to, or death of, personnel or long term health hazards.

CAUTION

Highlights essential operating or maintenance procedure, practice, condition, statement, etc. that if not strictly observed, could result in damage to, or destruction of equipment.

NOTE

Highlights essential operating or maintenance procedure, practice, condition, or statement.

1 General Information and Specifications

1.1 Specifications

1.1.1 General Specifications

The general, overall specifications are listed in the following table:

Table 1-1. General Specifications

Specification	Value
Lifting capacity	6,000 lb.
Lifting height	49-1/2 in. with adapters
Lowered height	4 in.
Overall length	88 in.
Overall width	39-1/2 in.
Lifting time	36 sec.
Pump output	3,200 psi
Fluid capacity	6 qt.
Motor	110vac, 1 hp

Lift Capacity Specifications

The lift capacity is what the lift will pick up with weight directly on the lifting pads at the specified distances from the floor. Refer to table 1-2 below.

Table 1-2. Lift Capacity Specifications

Weight	Scissor Lift Height	Conditions
1,500 lbs.	Fully retracted	No spacer on the platform attachment bolts
3,000 lbs.	1-1/2 in. from floor	With provided spacer on the platform attachment bolts
4,000 lbs.	2-1/2 in. from floor	Requires additional spacer
5,000 lbs.	3-3/8 in. from floor	Requires additional spacer
6,000 lbs.	4-3/8 in. from floor	Requires additional spacer

The remaining chapters in this manual are as follows:

Chapter/Title:	Page:
2 - Installation and Preparation for Use	2-1
3 - Operating Instructions	3-1
4 - Maintenance and Troubleshooting	4-1
5 - illustrated Parts Breakdown	5-4

2 Installation and Preparation for Use

2.1 General Information

1. Any freight damage must be noted on the freight bill before signing and reported to the freight carrier with a freight claim established. Identify the components and check for shortages. If shortages are discovered, contact your service technician immediately.
2. Consult building owner and / or architect's plans when applicable to establish the best lift location. The lift should be located on a relatively level floor with 4 in. minimum thickness, 3000-psi concrete slab that has been properly cured.
3. Make sure that the area where the lift will be located is free of obstructions for 12 ft. above the floor. This includes Heaters, building supports, conduits, etc.
4. Make sure there is adequate space to allow movement around the lift with a vehicle in place.

2.2 Tools and Equipment Required

The installation of this lift is relatively simple and can be accomplished by two men in a few hours. . Common mechanic's tools are all that are required.

2.3 Foundation Requirements

The foundation has to be long enough for the vehicles to be supported, wide enough to provide support for the lift with adequate working space on all sides. The concrete shall have compression strength of at least 3,000 PSI and a minimum thickness of 4 in. (6 in. recommended)

2.4 Installation

Install as given in the following paragraphs.

2.4.1 Mount Motor and Pump

Refer to figure 2-1 on page 2-2 and mount the motor and pump (item 44.1) to the dolly with the hardware listed below:

ITEM	PART NUMBER	DESCRIPTION
26	GB95-85-8	FLAT WASHER
27	GB93-87-8	LOCK WASHER
44.5	GB5781-86-8MM X 25MM	BOLT 8MM X 25MM
53	GB41-86-8	NUT

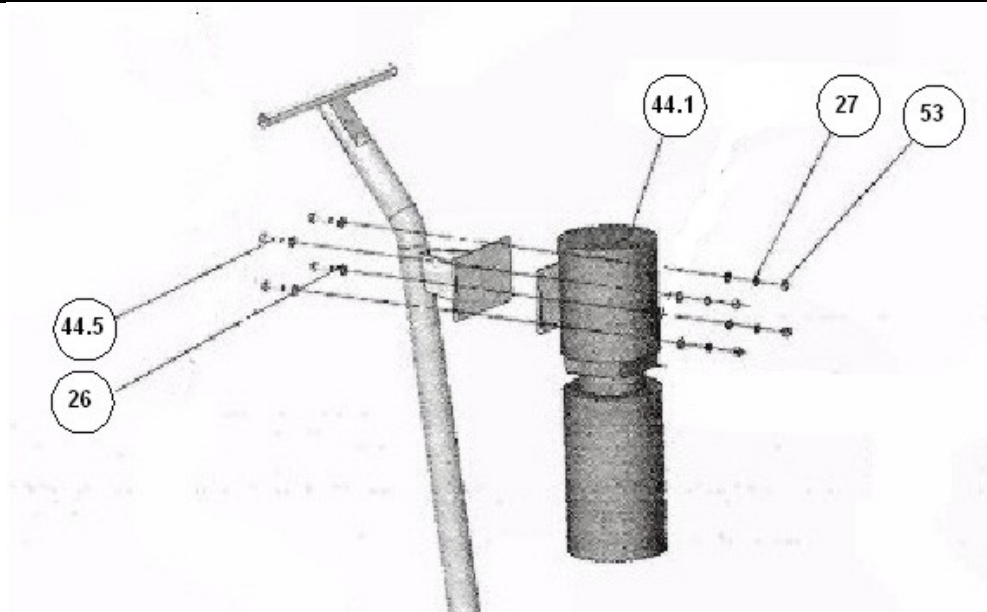

Figure 2-1. Motor and Pump Mounting

2.4.2 Hydraulics and Safety Cable Installation and Servicing

Refer to figure 2-2 on page 2-4, and using the following parts install and service the hydraulics as given in the steps below the parts listing:

ITEM	PART NUMBER	DESCRIPTION
19	PMR-6020	HYDRAULIC HOSE
20	30400-9054 B)	45° FITTING
39	PMR-6030	SAFETY RELEASE CABLE
44.2	51053-1811	HANDLE
44.3	PMR-6030	SAFETY RELEASE HANDLE
44.8	30400-9053YZ	FITTING

1. Install hydraulic fitting (item 44.8) in the port on the hydraulic power unit.
2. Connect the hydraulic hose (item 19) to the fitting installed in step 1 and to the 45° fitting (item 20) on the lift.
3. Remove cap from the pump reservoir and fill reservoir tank with ISOVG32 hydraulic oil.
4. Electrical
 - A. SINGLE PHASE 208-230V

Have a certified electrician establish 208-230V, single phase, 60 Hz power supply with 20 amp time delay fuse to motor figure 7.

Use separate circuits for each power unit.

Single phase motor cannot be run on 50 Hz. line without modifications in the motor.

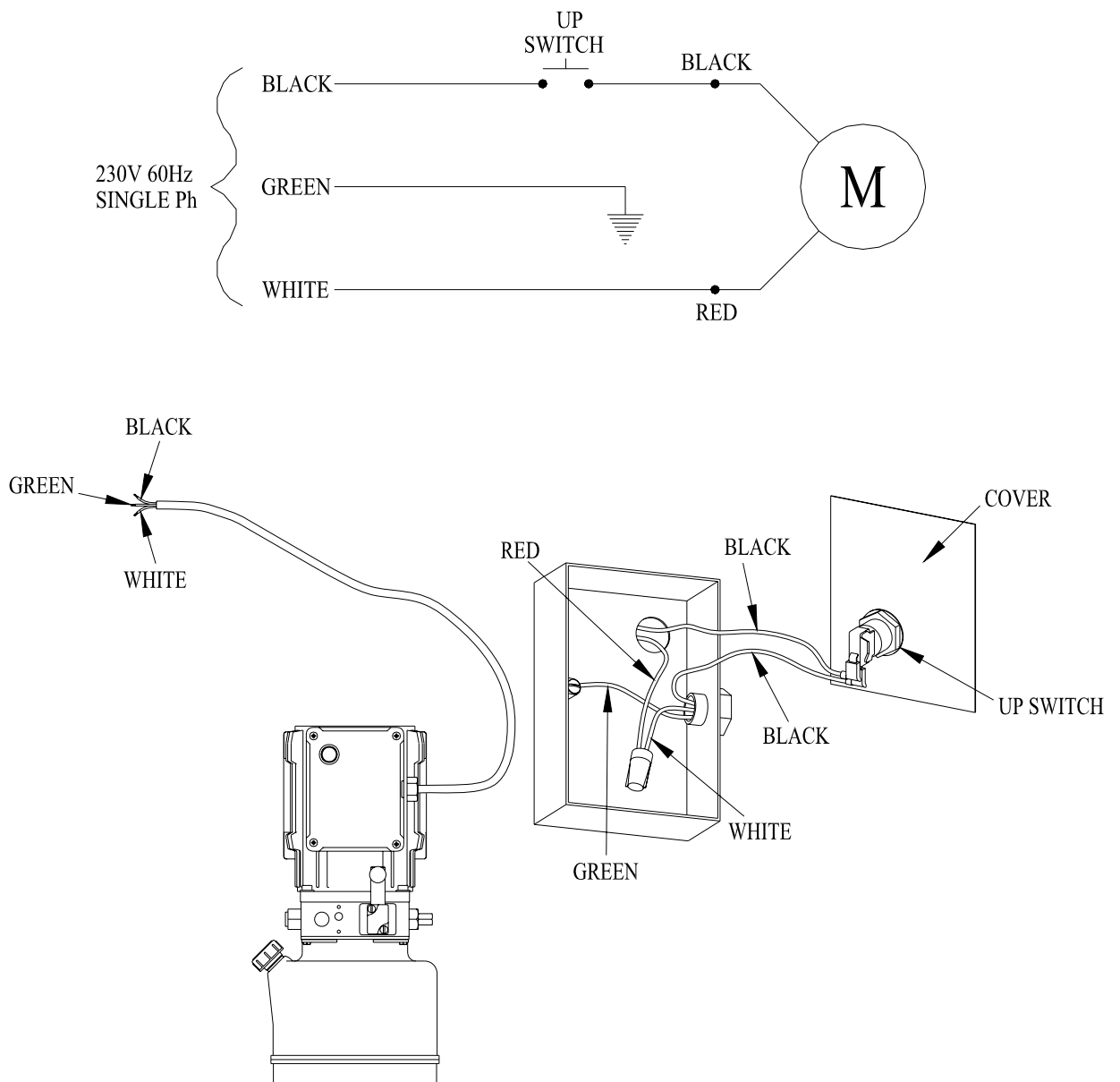

B. For 110V Power Units, lug unit into a 110 volt AC power source

NOTE

In the following step, the safety release cable should already be installed at the lock end of the lift.

4. Attach the other end of the safety release cable (item 39) to the safety release handle (item 44.3), and mount to the power unit stand handle (item 44.2).

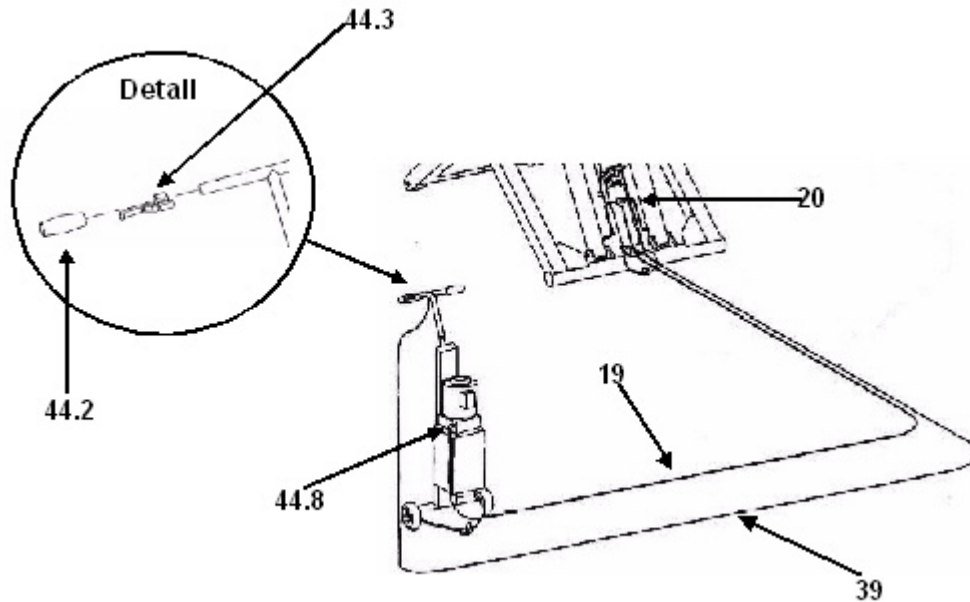

Figure 2-2. Hydraulics and Safety Cable Installation and Servicing

2.5 Installation test

Test the Lift operation by doing the following (requires a vehicle):

1. Push “up” switch to a position where the vehicle is just leaving the ground.
2. Raise lift only HALF WAY then lower completely at least one dozen times.
3. Raise lift to its extreme position and inspect. Make sure that there are no hydraulic leaks. Test Mechanical locks. Make sure that the lift holds vehicle in steady position without lowering.
4. Raise lift slightly and push lock release handle. Check that lift lowers smoothly and at a safe speed.
5. Repeat above procedures to make sure that lift is operating normally.

NOTE

During the initial testing, the lift will descend slowly. This is normal. It helps to add a payload, no greater than 500 pounds to help speed up the decent during this process.

6. Check all hoses for leaks. Tighten if necessary.

3 Operating Instructions

3.1 Safety Procedures

WARNING

Failure to adhere to the following can result in death or injury, or damage to the equipment and vehicle. All personnel will be made aware of this warning and trained in the use and care of the lift.

1. Never allow unauthorized persons to operate lift. Thoroughly train new employees in the use and care of lift.
2. Lift should only be operated on a level foundation.
3. Caution - the power unit operates at high pressure.
4. Remove passengers before raising vehicle.
5. Prohibit unauthorized persons from being in shop area while lift is in use.
6. Do not exceed the lift's capacity.
7. Prior to lifting vehicle, walk around the lift and check for any objects that might interfere with the operation of lift, such as tools, air hoses, and shop equipment. Remove any potential obstacles that might impede roller travel.
8. Always lift vehicle using all four pads.
9. Never use lift to raise one end or one side of vehicle.
10. Raise vehicles about three in. and check stability by rocking.
11. Always lock the lift before going under the vehicle. Never allow anyone to go under the lift when raising or lowering.
12. The vehicle's center of gravity should be balanced on the lift.
13. Do not remove heavy components from a raised machine or vehicle without first installing adequate supports. The vehicle may become unbalanced and fall.

3.2 Daily Pre-Operation Check (8-Hours)

NOTE

Occupational Safety and Health Administration (OSHA) and the American National Standards Institute (ANSI) require users to inspect lifting equipment at the start of every shift. These and other periodic inspections are the responsibility of the user.

WARNING

Failure to perform the daily pre-operational check can result in expensive property damage, lost production time, serious personal injury, and even death. The safety latch system must be checked and working properly before the lift is put to use.

The daily pre-operational check consists of the following:

1. Check hydraulic connections, and hoses for leakage.
2. Make sure all bolts are secured and snug with lock washer, nylon lock nuts, or cotter keys.
3. Lift locking mechanism should be lubricated to operate properly.
4. Check spring on locking mechanism for constant tension.
5. Check oil level in pump reservoir.
6. Always keep the lift platforms clean and do not use the lift if it has oil, dirt or mud on it.

3.3 Controls

The controls are located on the power unit on the lift dolly. They are shown in figure 3-1 and their use and function given in table 3-1 below.

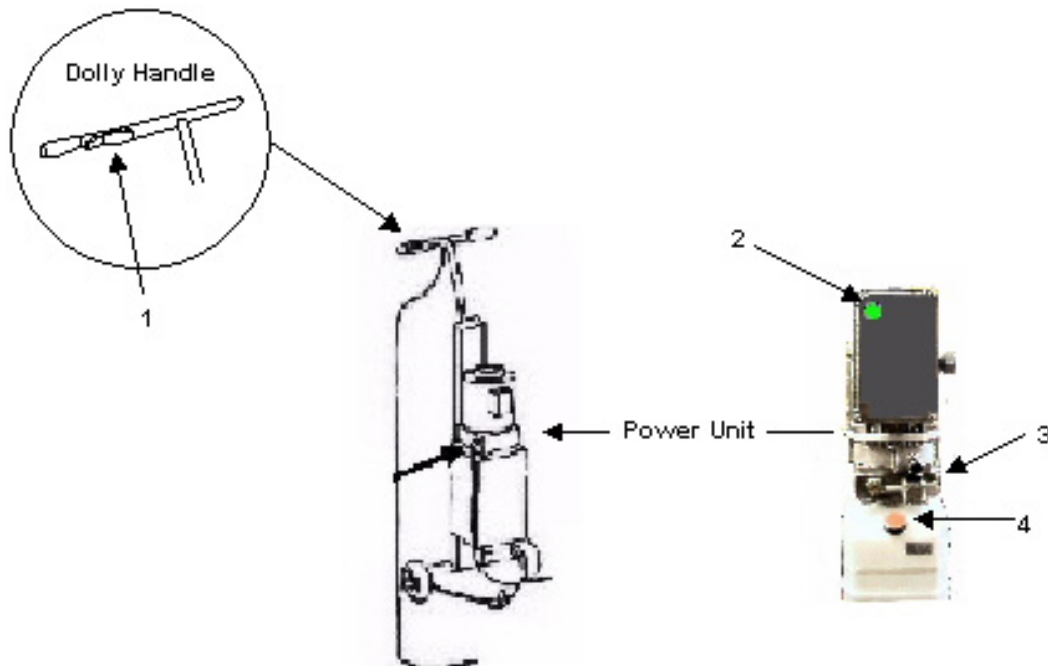

Figure 3-1. Controls

Table 3-1. Controls

Item No.	Type	Purpose
1	Safety Release Handle	Used to disengage the safety lock prior to lowering the lift
2	Push button switch	Controls electrical power to the power unit. Push to turn-on, and push again to turn-off the power unit. Lights when ON.
3	Lowering Handle	Used to relieve hydraulic pressure when pressed down.
4	Reservoir cap	Cap for the power unit fluid reservoir. Remove to add fluid.

3.4 Operation

Operate the lift as given in the following paragraphs.

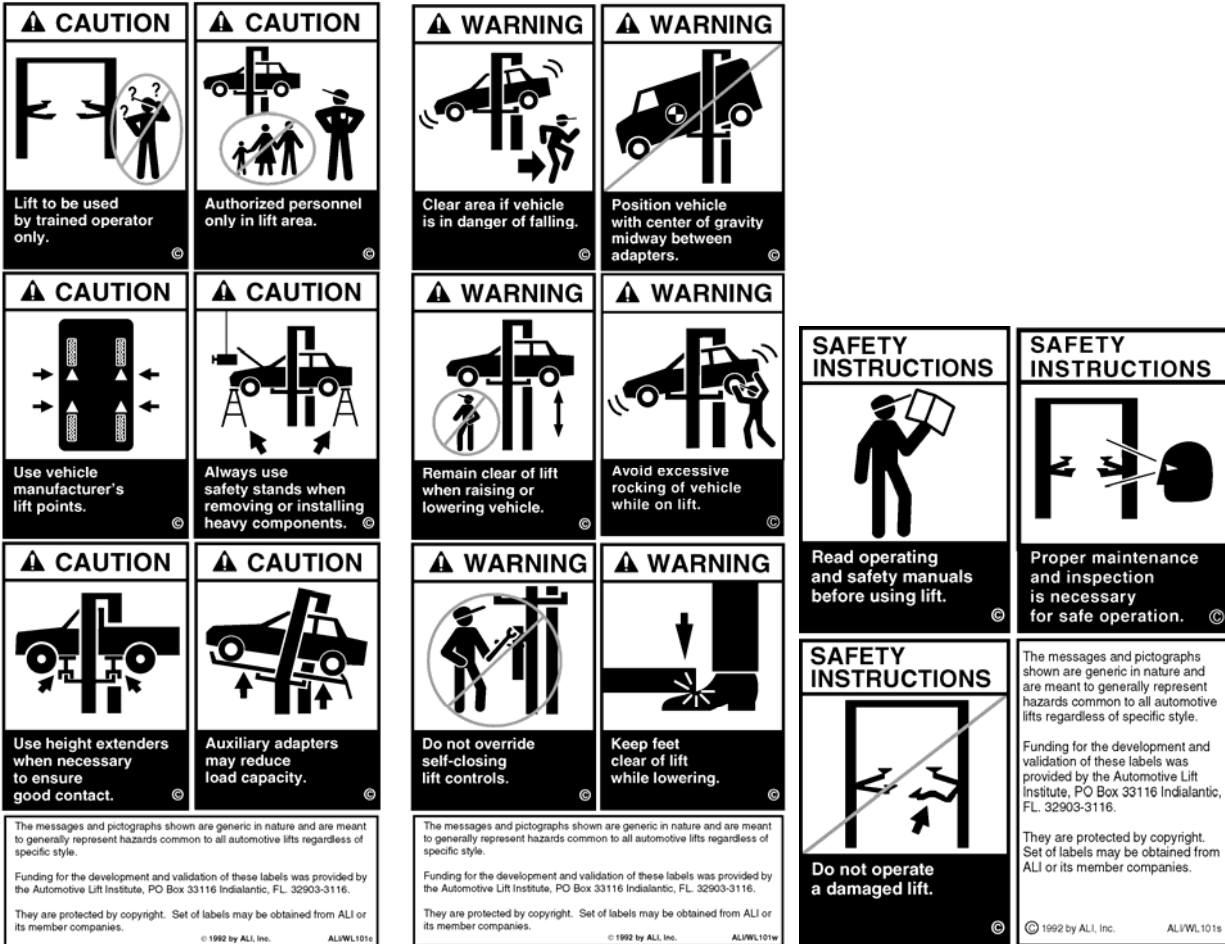

The Owner/Employer:

- Shall ensure that lift operators are qualified and that they are trained in the safe use and operation of the lift using the manufacturer's operating instructions; ALI/SM01-1, ALI Lifting it Right safety manual; ALI/ST-90 ALI Safety Tips card; ANSI/ALI ALOIM-2000, American National Standard for Automotive Lifts-Safety Requirements for Operation, Inspection and Maintenance; ALI/WL Series, ALI Uniform Warning Label Decals/Placards; and in the case of frame engaging lifts, ALI/LP-GUIDE, Vehicle Lifting Points/Quick Reference Guide for Frame Engaging Lifts.
- Shall establish procedures to periodically inspect the lift in accordance with the lift manufacturer's instructions or ANSI/ALI ALOIM-2000, American National Standard for Automotive Lifts-Safety Requirements for Operation, Inspection and Maintenance; and The Employer Shall ensure that lift inspectors are qualified and that they are adequately trained in the inspection of the lift.

-
- Shall establish procedures to periodically maintain the lift in accordance with the lift manufacturer's instructions or ANSI/ALI ALOIM-2000, American National Standard for Automotive Lifts-Safety Requirements for Operation, Inspection and Maintenance; and The Employer Shall ensure that lift maintenance personnel are qualified and that they are adequately trained in the maintenance of the lift.
 - Shall maintain the periodic inspection and maintenance records recommended by the manufacturer or ANSI/ALI ALOIM-2000, American National Standard for Automotive Lifts-Safety Requirements for Operation, Inspection and Maintenance.
 - Shall display the lift manufacturer's operating instructions; ALI/SM 93-1, ALI Lifting it Right safety manual; ALI/ST-90 ALI Safety Tips card; ANSI/ALI ALOIM-2000, American National Standard for Automotive Lifts-Safety Requirements for Operation, Inspection and Maintenance; and in the case of frame engaging lifts, ALI/LP-GUIDE, Vehicle Lifting Points/Quick Reference Guide for Frame Engaging Lifts; in a conspicuous location in the lift area convenient to the operator.
 - Shall provide necessary lockout/tagout means for energy sources per ANSI Z244.1-1982 (R1993), Safety Requirements for the Lockout/Tagout of Energy Sources, before beginning any lift repairs.
 - Shall not modify the lift in any manner without the prior written consent of the manufacturer.

Lift Lockout/Tagout Procedure

Purpose

This procedure establishes the minimum requirements for the lockout of energy that could cause injury to personnel by the operation of lifts in need of repair or being serviced. All employees shall comply with this procedure.

Responsibility

The responsibility for assuring that this procedure is followed is binding upon all employees and service personnel from outside service companies (i.e., Authorized Installers, contactors, etc.). All employees shall be instructed in the safety significance of the lockout procedure by the facility owner/manager. Each new or transferred employee along with visiting outside service personnel shall be instructed by the owner/manager (or assigned designee) in the purpose and use of the lockout procedure.

Preparation

Employees authorized to perform lockout shall ensure that the appropriate energy isolating device (i.e., circuit breaker, fuse, disconnect, etc.) is identified for the lift being locked out. Other such devices for other equipment may be located in close proximity of the appropriate energy isolating

device. If the identity of the device is in question, see the shop supervisor for resolution. Assure that proper authorization is received prior to performing the lockout procedure.

Sequence of Lockout Procedure

- 1) Notify all affected employees that a lockout is being performed and the reason for it.
- 2) Unload the subject lift. Shut it down and assure the disconnect switch is “OFF” if one is provided on the lift.
- 3) The authorized lockout person operates the main energy isolation device removing power to the subject lift.
 - If this is a lockable device, the authorized lockout person places the assigned padlock on the device to prevent its unintentional reactivation. An appropriate tag is applied stating the person’s name, at least 3” x 6” in size, an easily noticeable color, and states not to operate device or remove tag.
 - If this device is a non-lockable circuit breaker or fuse, replace with a “dummy” device and tag it appropriately as mentioned above.
- 4) Attempt to operate lift to assure the lockout is working. Be sure to return any switches to the “OFF” position.

Restoring Equipment to Service

- 1) Assure the work on the lift is complete and the area is clear of tools, vehicles, and personnel.
- 2) At this point, the authorized person can remove the lock (or dummy circuit breaker or fuse) & tag and activate the energy isolating device so that the lift may again be placed into operation.

Rules for Using Lockout Procedure

Use the Lockout Procedure whenever the lift is being repaired or serviced, waiting for repair when current operation could cause possible injury to personnel, or for any other situation when unintentional operation could injure personnel. No attempt shall be made to operate the lift when the energy isolating device is locked out.

7. Operating Conditions

Lift is not intended for outdoor use and has an operating ambient temperature range of 41°-104°F (5°-40°C).

3.4.1 Raising Vehicle

Raise the vehicle as follows:

1. Drive car onto the lift and check if the car is placed in appropriate position. Relocate lift or vehicle as required.

NOTE: Some vehicles may have the manufacturer's Service Garage Lift Point locations identified by triangle shape marks on it's undercarriage (reference ANSI/SAE J2184-1992). Also, there may be a label located on the right front door lock face showing specific vehicle lift points. If the specific vehicle lift points are not identified, refer to the "Typical Lift Points" illustrated herein or the ANSI/ALI Lifting Point Guide included with your lift. ALWAYS follow the operating instructions supplied with the lift.

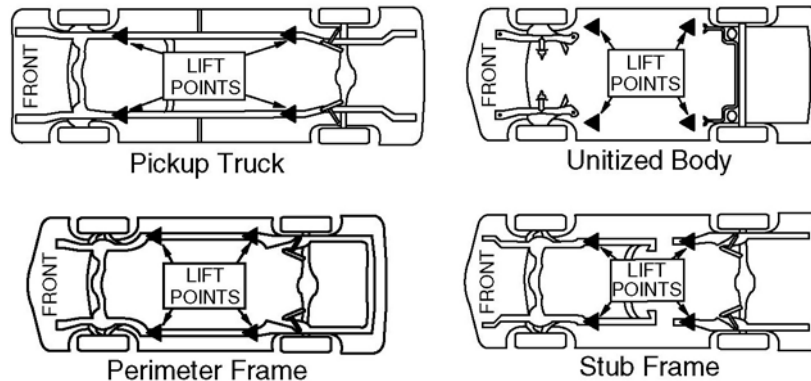

Typical Lift Points Diagram

2. Place the four lifting pads into place in the Mounting hole at the end of each lifting arm.
3. Locate lift pads at appropriate lifting points under vehicle.
4. Push "up" switch until the lift reaches a position to where the vehicle is just leaving the ground.
5. Inspect to make sure there is no interference with any other objects.
6. Check proper engagement of lifting pads on vehicle. Make sure that vehicle is horizontal on lift.
7. Shake moderately at front or rear bumper.
8. Raise vehicle to desired height then lower onto lock. Make sure that the lift holds the vehicle in steady position without lowering.

3.4.2 Lowering Vehicle

Lower the vehicle by doing the following:

1. Prior to lowering vehicle, walk around the lift and check for any objects that might interfere with the operation of lift such as tools, air hoses, and shop equipment.
2. Reconnect electrical power to the power unit.
3. Raise lift slightly and push lock release handle.
4. Check that lift lowers smoothly and at a safe speed.
5. Allow the lift to fully lower and lock the lift.
6. Swing the arms out of the way and slowly drive the vehicle out. Have some one outside the vehicle guide the driver.

4 Maintenance and Troubleshooting

4.1 Maintenance

4.1.1 Periodic Maintenance Schedule

The periodic maintenance given in the following paragraphs is the suggested minimum requirements and minimum intervals; accumulated hours or monthly period, whichever ever comes sooner.

WARNING

Failure to heed this warning can result in death or serious injury, or damage to equipment. If you hear a noise not associated with normal lift operation, or, if there is any indication of impending lift failure - **CEASE OPERATION IMMEDIATELY!** - Inspect, correct and/or replace parts as required.

Periodic maintenance is to be performed on a daily, weekly, and yearly basis as given in the following paragraphs.

4.1.1.1 Daily Pre-Operation Check (8-Hours)

NOTE

Occupational Safety and Health Administration (OSHA) and the American National Standards Institute (ANSI) require users to inspect lifting equipment at the start of every shift. These and other periodic inspections are the responsibility of the user.

WARNING

Failure to perform the daily pre-operational check can result in expensive property damage, lost production time, serious personal injury, and even death. The safety latch system must be checked and working properly before the lift is put to use.

The daily pre-operational check consists of the following:

7. Check hydraulic connections, and hoses for leakage.
8. Make sure all bolts are secured and snug with lock washer, nylon lock nuts, or cotter keys.
9. Lift locking mechanism should be lubricated to operate properly.
10. Check spring on locking mechanism for constant tension.
11. Check oil level in pump reservoir.
12. Always keep the lift platforms clean and do not use the lift if it has oil, dirt or mud on it.

4.1.1.2 Monthly Maintenance (every month)

On a monthly basis, perform the following checks:

-
1. Inspect all hydraulic components for leaks, deformation, wear or corrosion.
 2. Tighten all fasteners, screws and hydraulic fittings as required.
 3. Check all wire connections. Make sure wires are connected properly.
 4. Check hydraulic fluid. If it is dirty, replace with clean fluid. Always use a clean funnel and filter.
 5. Inspect for cracks in the lock mechanism, and on other parts of the lift. Replace parts as needed.
 6. Check for rust on parts. Remove rust, lubricate and paint as needed.
 - 7.

4.1.1.3 Special Maintenance Tasks

The following items should only be performed by a trained maintenance expert.

1. Replacement of hydraulic hoses.
2. Replacement or rebuilding air and hydraulic cylinders as required.
3. Replacement or rebuilding pumps / motors as required.
4. Checking of hydraulic cylinder rod and rod end (threads) for deformation or damage.

NOTE

Relocating or changing components may cause problems. Each component in the system must be compatible; an undersized or restricted line will cause a drop in pressure. All valve, pump, and hose connections should be sealed and/or capped until just prior to use. Air hoses can be used to clean fittings and other components. However, the air supply must be filtered and dry to prevent contamination. Most important - cleanliness - contamination is the most frequent cause of malfunction or failure of hydraulic equipment.

4.2 Troubleshooting

The common problems that may be encountered and their probable causes are covered in the following paragraphs:

<u>Paragraph:</u>	<u>Problem:</u>	<u>Page:</u>
4.2.1	Motor does not operate	4-2
4.2.2	Lift mechanism does not move up and down smoothly.	4-3
4.2.3	Lift does not lift its rated capacity.	4-3
4.2.4	Cylinders leak under rated load	4-3
4.2.5	Lift will not lower	4-3

4.2.1 Motor Does Not Operate

Failure of the motor to operate is normally caused by one of the following:

1. Check electrical plug and cord.
2. Check electrical supply breaker
3. Faulty wiring connections; call electrician.
4. Faulty power unit switch. Contact the manufacturer for a replacement or additional troubleshooting information.

4.2.2 Lift Mechanism Does Not Move Up and Down Smoothly.

If the lift mechanism does not move up and down smoothly do the following:

1. Move vehicle location on the lift for more equal weight distribution.
2. Bleed the hydraulic system by first loosening the hose connection at the rod end of both cylinders. Then loosen the hose from fitting (NOT the fitting from the cylinder). Run the power unit until fluid appears at the hose and fitting connection and hose connection at the rod end. When there is no more air exiting the system, tighten both hose connections.

4.2.3 Lift Does Not Lift its Rated Capacity.

If the lift fails to lift its rated capacity try the following:

1. Move vehicle location on the lift for more equal weight distribution.
2. Check the voltage of the electrical supply with the unit run under load. Make sure the pump is getting adequate voltage.

4.2.4 Cylinders Leak under Rated Load.

If the cylinders leak under rated load check the following:

1. Check for leaks at the hydraulic hose, fittings, cylinders and pump.
2. Contamination may be in the check valve preventing the valve from completely closing. Clear as follows:
 - a) Hold open the lowering valve by pushing the control lever on the power unit.
 - b) At the same time, run the pump for 30 seconds to flush the valve.
 - c) Repeat 3 to 4 times.
 - d) If cylinders continue to leak down, pump may have a faulty valve. Contact the manufacturer.

4.2.5 Lift will not lower.

If the lift fails to lower, do the following:

1. Raise lift 1 in. to 2 in., squeeze release handle and try again to lower lift.
2. Check tension on the release cable.

5 Illustrated Parts Breakdown

Use the complete parts listing in paragraph 5-2 to perform inventory before assembly of the lift.

5.1 Illustrated Parts Breakdown Information

This paragraph consists of the detailed illustrations and parts listings for the lift. Certain parts may be shown on more than one figure in order to illustrate their relationship with other components shown in the figure. The illustrations are shown on the left-hand pages with their corresponding parts listing shown on the right-hand pages.

NOTE

The part quantities shown are the totals for that part contained within the entire lift. Therefore, the quantities shown may be greater than what is shown on an individual sheet of the IPB illustrations

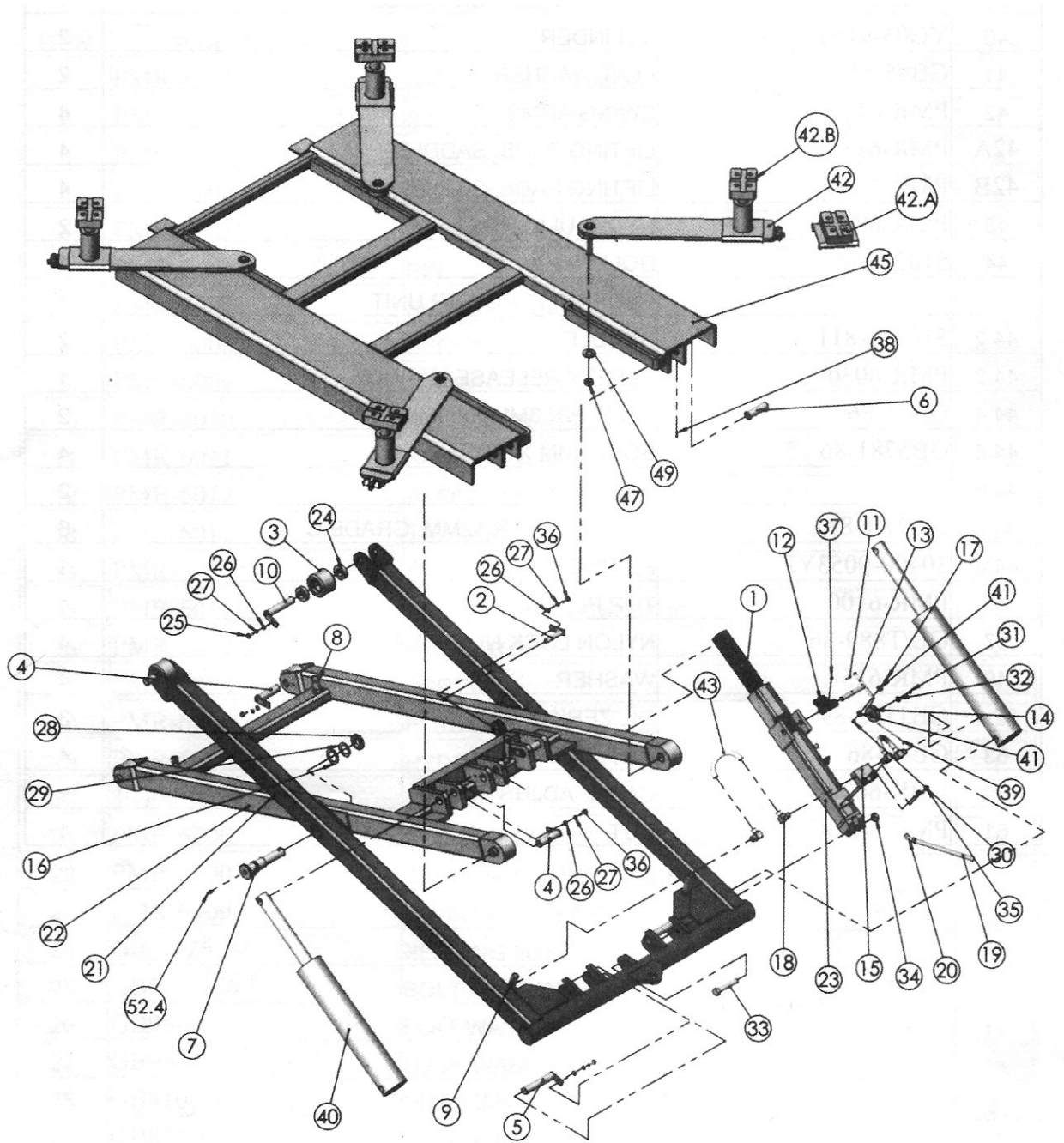

Figure 5-1. Illustrated Parts Breakdown – Sheet 1 of 3

Table 5-1. Parts Listing – Page 1 of 3

ITEM	PART NUMBER	DESCRIPTION	QTY
1	PMR-6001	SAFETY GEAR RACK	1
2	PMR-6002	PIN	1
3	PMR-6003	ROLLER	4
4	PMR-6004	PIN, FLOOR ROLLER	4
5	PMR-6005	CYLINDER BOTTOM PIN	2
6	PMR-6006	PIN	2
7	PMR-6007	SCISSOR PIN	2
8	PMR-6008	SPRING	2
9	PMR-6009	SPRING	2
10	PMR-6010	PIN, TOP ROLLER	2
11	PMR-6011	SPRING, LATCH RESET	1
12	PMR-6012	SAFETY LATCH	1
13	PMR-6013	T SHAFT, LATCH	1
14	PMR-6015	CABLE PULLEY	1
15	PMR-6016	TEE FITTING, HYDRAULIC	1
16	PMR-6017	WASHER	2
17	PMR-6018	SCREW	1
18	PMR-6019	ELBOW FITTING	4
19	PMR-6020	HYDRAULIC HOSE	1
20	30400-9054 B	45° FITTING	1
22	PMR-6300	SCISSOR FRAME, INSIDE	1
23	PMR-6400	CHANNEL, SAFETY	1
24	GB/T126-94	BEARING 6005	8
25	GB5781-86- M8 X 16MM	BOLT M8 X 16MM	4
26	GB95-85	FLAT WASHER	17
27	GB93-87	LOCK WASHER	13
28	GB810-88-30MM X 1.5	NUT 30MM X 1.5	2
29	GB858-88-30	LOCK WASHER 30MM	2
30	GB923-88-6	NUT 6MM	1
31	GB67-85-6MM X 10	SLOTTED NUT 6MM X 10	1
32	GB96-85	WASHER	1
33	GB5782-86-16MM X 80MM	BOLT 16MM X 80MM, GRADE 8.8	1
34	GB/T889-86-16	NYLON LOCK NUT 16MM	1
35	GB70-85-18MM X 16MM	BOLT 8MM X 16MM	2
36	GB5781-86-8MM X 20MM	BOLT 8MM X 20MM	5
37	GB70-85-5MM X 16MM	BOLT 5MM X 16MM	1
38	GB77-85-8MM X 16MM	BOLT 8MM X 16MM	4
39	PMR-6030	SAFETY RELEASE CABLE	1
40	YG03-9100	CYLINDER	2
41	GB95-85	FLAT WASHER	2
42	PMR-6150	SWING ARMS	4
42A	PMR-6130	LIFTING PADS, SADDLE	4
42B	PMR-6140	LIFTING PADS, SCRWE	4
43	PMR-6021	HYDRAULIC HOSE	2

Table 5-1. Parts Listing – Page 1 of 3 (Cont.)

ITEM	PART NUMBER	DESCRIPTION	QTY
45	PMR-6100	TOP PLATFORM	1
47	GB/T889-86-18	NYLON LOCK NUT 18MM	4
49	PMR-6158	WASHER	4
52.4	GB1152-89	OIL ZERK	3

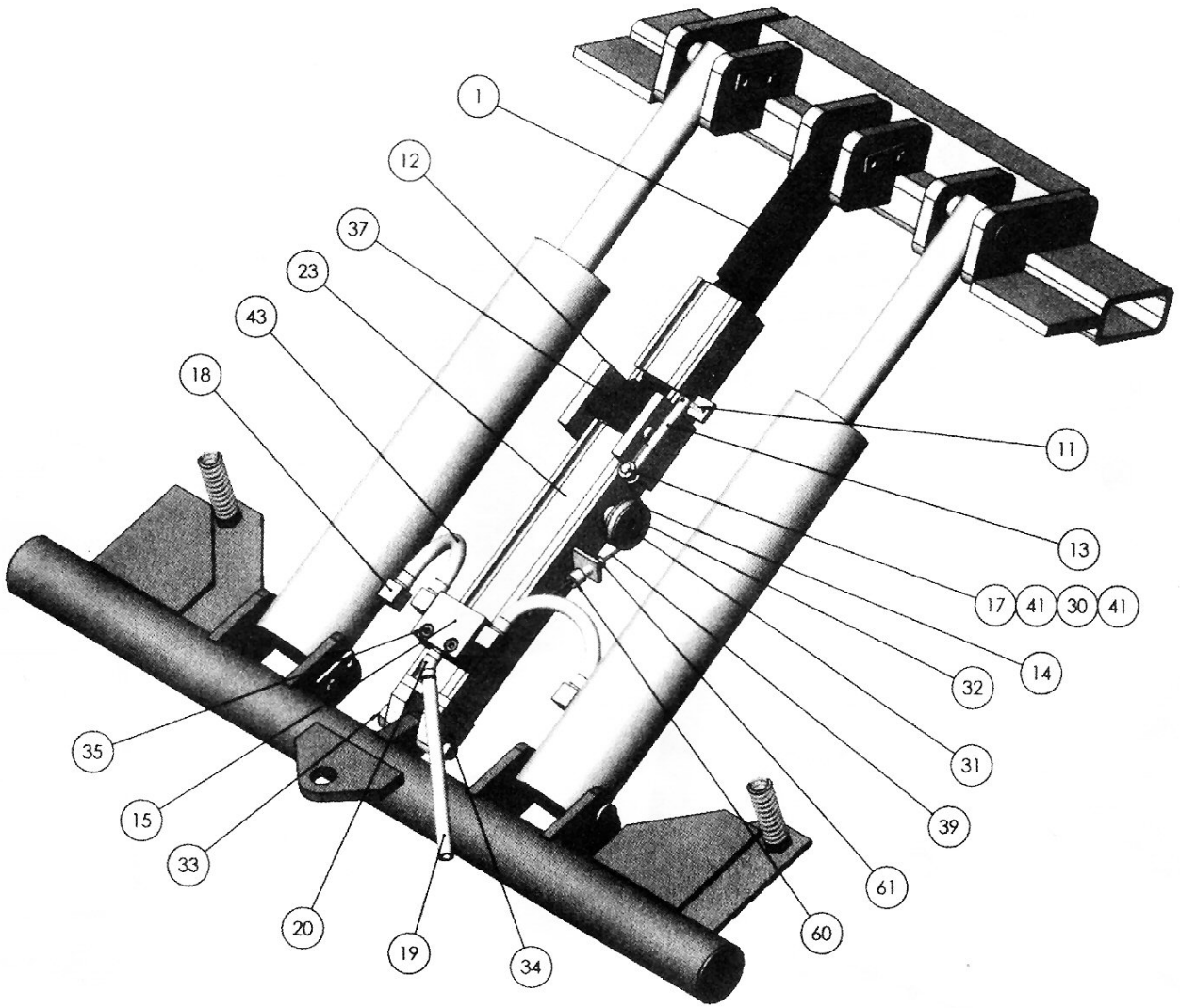

Figure 5-1. Illustrated Parts Breakdown – Sheet 2 of 3

Table 5-1. Parts Listing – Page 2 of 3

ITEM	PART NUMBER	DESCRIPTION	QTY
1	PMR-6001	SAFETY GEAR RACK	1
11	PMR-6011	SPRING, LATCH RESET	1
12	PMR-6012	SAFETY LATCH	1
13	PMR-6013	T SHAFT, LATCH	1
14	PMR-6015	CABLE PULLEY	1
15	PMR-6016	TEE FITTING, HYDRAULIC	1
17	PMR-6018	SCREW	1
18	PMR-6019	ELBOW FITTING	4
19	PMR-6020	HYDRAULIC HOSE	1
20	30400-9054 B	45° FITTING	1
23	PMR-6400	CHANNEL, SAFETY	1
30	GB923-88-6	NUT 6MM	1
31	GB67-85-6MM X 10	SLOTTED NUT 6MM X 10	1
32	GB96-85	WASHER	1
33	GB5782-86-16MM X 80MM	BOLT 16MM X 80MM, GRADE 8.8	1
34	GB/T889-86-16	NYLON LOCK NUT 16MM	1
35	GB70-85-18MM X 16MM	BOLT 8MM X 16MM	2
37	GB70-85-5MM X 16MM	BOLT 5MM X 16MM	1
39	PMR-6030	SAFETY RELEASE CABLE	1
41	GB95-85	FLAT WASHER	2
43	PMR-6021	HYDRAULIC HOSE	2
60	PMR-6030B	CABLE ADJUST BOLT	1
61	PMR-6030C	NUT	1

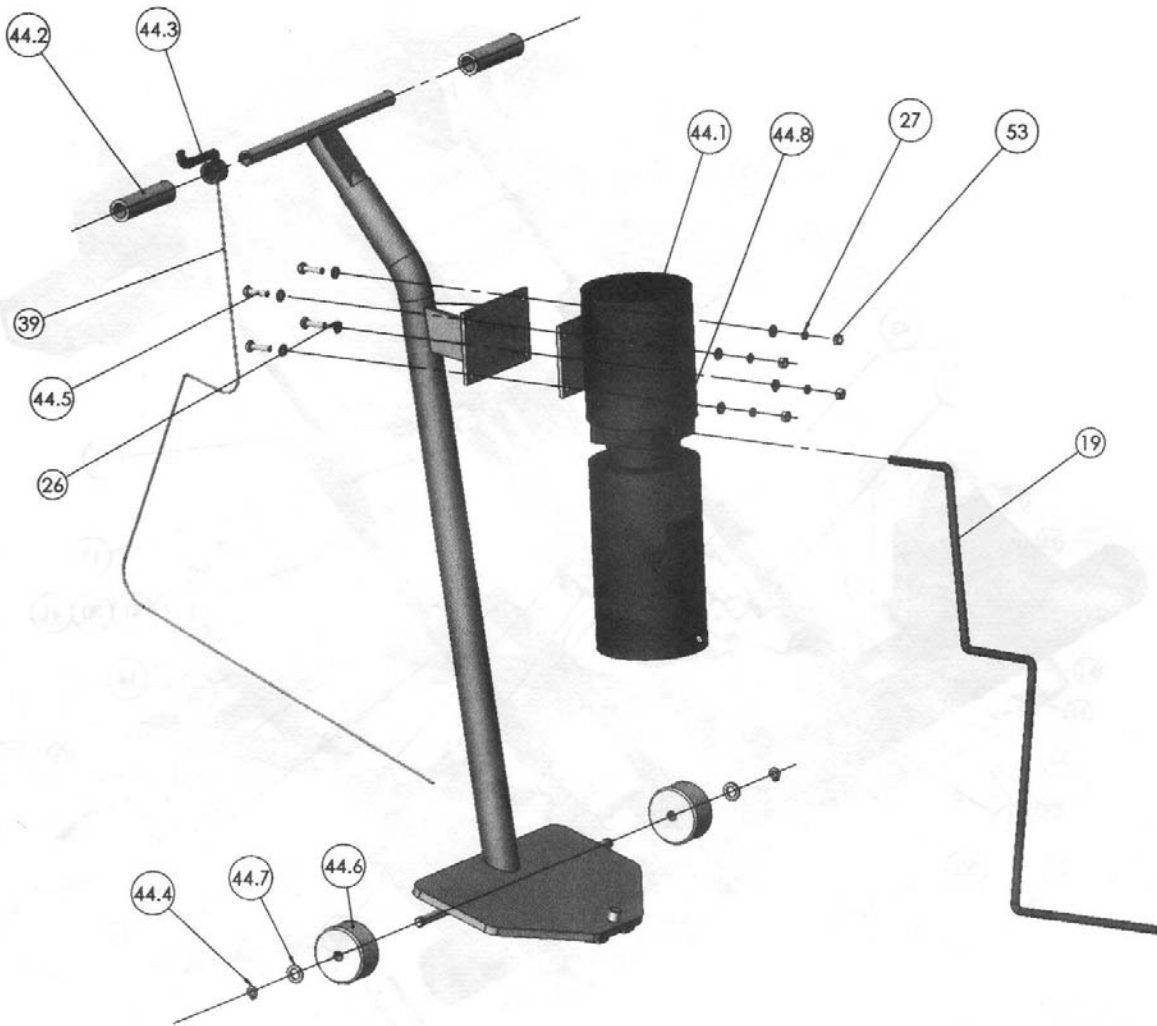

Figure 5-1. Illustrated Parts Breakdown – Sheet 3 of 3

Table 5-1. Parts Listing – Page 3 of 3

ITEM	PART NUMBER	DESCRIPTION	QTY
19	PMR-6020	HYDRAULIC HOSE	1
26	GB95-85	FLAT WASHER	17
27	GB93-87	LOCK WASHER	13
39	PMR-6030	SAFETY RELEASE CABLE	1
44.1	WT-1	HYDRAULIC POWER UNIT	1
44.2	51053-1811	HANDLE	2
44.3	PMR-6030	SAFETY RELEASE HANDLE	1
44.4	GB91-86-3MM X 30MM	SPLIT PIN 3MM X 30MM	2
44.5	GB5781-86-8MM X 25MM	BOLT 8MM X 25MM	4
44.6		CASTERS	2
44.7	GB97.1-85-12	FLAT WASHER 12MM, GRADE C	6
44.8	30400-9053YZ	FITTING	1
53	GB41-86	NUT	4

5.2 Complete Parts Listing

The lift consists of two hardware bags and the remainder of the lift parts. When inventorying the hardware bags **do not** mix the parts in the two bags together. Return them to the original bags. The master or complete parts' listing is shown in paragraph 5.2.2.

5.2.1 Hardware Bag #1

Hardware Bag # 1 contains the items listed in table 5-2. Item numbers shown are those as shown on the master parts listing.

Table 5-2. Hardware Bag #1 Contents

ITEM	PART NUMBER	DESCRIPTION	QTY
26	GB95-85-8	FLAT WASHER	8
27	GB93-87-8	LOCK WASHER	4
28	GB810-88-30MM X 1.5	NUT 30MM X 1.5	4
44.5	GB5781-86-8MM X 25MM	BOLT 8MM X 25MM	4
44.8	30400-9053YZ	FITTING	1

5.2.2 Master (Complete) Parts Listing

The Master (Complete) Parts Listing is given in table 5-3 below.

Table 5-3. Master (Complete) Parts Listing

ITEM	PART NUMBER	DESCRIPTION	QTY
1	PMR-6001	SAFETY GEAR RACK	1
2	PMR-6002	PIN	1
3	PMR-6003	ROLLER	4
4	PMR-6004	PIN, FLOOR ROLLER	4
5	PMR-6005	CYLINDER BOTTOM PIN	2
6	PMR-6006	PIN	2
7	PMR-6007	SCISSOR PIN	2
8	PMR-6008	SPRING	2
9	PMR-6009	SPRING	2
10	PMR-6010	PIN, TOP ROLLER	2
11	PMR-6011	SPRING, LATCH RESET	1
12	PMR-6012	SAFETY LATCH	1
13	PMR-6013	T SHAFT, LATCH	1
14	PMR-6015	CABLE PULLEY	1
15	PMR-6016	TEE FITTING, HYDRAULIC	1
16	PMR-6017	WASHER	2
17	PMR-6018	SCREW	1
18	PMR-6019	ELBOW FITTING	4
19	PMR-6020	HYDRAULIC HOSE	1
20	30400-9054 B	45° FITTING	1
22	PMR-6300	SCISSOR FRAME, INSIDE	1
23	PMR-6400	CHANNEL, SAFETY	1
24	GB/T126-94	BEARING 6005	8
25	GB5781-86- M8 X 16MM	BOLT M8 X 16MM	4
26	GB95-85-8	FLAT WASHER	17
27	GB93-87-8	LOCK WASHER	13

Table 5-3. Master (Complete) Parts Listing (Cont.)

ITEM	PART NUMBER	DESCRIPTION	QTY
28	GB810-88-30MM X 1.5	NUT 30MM X 1.5	2
29	GB858-88-30	LOCK WASHER 30MM	2
30	GB923-88-6	NUT 6MM	1
31	GB67-85-6MM X 10	SLOTTED NUT 6MM X 10	1
32	GB96-85	WASHER	1
33	GB5782-86-16MM X 80MM	BOLT 16MM X 80MM, GRADE 8.8	1
34	GB/T889-86-16	NYLON LOCK NUT 16MM	1
35	GB70-85-18MM X 16MM	BOLT 8MM X 16MM	2
36	GB5781-86-8MM X 20MM	BOLT 8MM X 20MM	5
37	GB70-85-5MM X 16MM	BOLT 5MM X 16MM	1
38	GB77-85-8MM X 16MM	BOLT 8MM X 16MM	4
39	PMR-6030	SAFETY RELEASE CABLE	1
40	YG03-9100	CYLINDER	2
41	GB95-85	FLAT WASHER	2
42	PMR-6150	SWING ARMS	4
42A	PMR-6130	LIFTING PADS, SADDLE	4
42B	PMR-6140	LIFTING PADS, SCRWE	4
43	PMR-6021	HYDRAULIC HOSE	2
44	51053-1800	DOLLY	1
44.1	WT-1	HYDRAULIC POWER UNIT	1
44.2	51053-1811	HANDLE	2
44.3	PMR-6030	SAFETY RELEASE HANDLE	1
44.4	GB91-86-3MM X 30MM	SPLIT PIN 3MM X 30MM	2
44.5	GB5781-86-8MM X 25MM	BOLT 8MM X 25MM	4
44.6		CASTERS	2
44.7	GB97.1-85-12	FLAT WASHER 12MM, GRADE C	6
44.8	30400-9053YZ	FITTING	1
45	PMR-6100	TOP PLATFORM	1
47	GB/T889-86-18	NYLON LOCK NUT 18MM	4
49	PMR-6158	WASHER	4
52.4	GB1152-89	OIL ZERK	3
53	GB41-86-8	NUT	4
60	PMR-6030B	CABLE ADJUST BOLT	1
61	PMR-6030C	NUT	1